

CAPACITY	SYMBOL/ SERIAL NO.	CIRCUIT DIAGRAM
DC 24V		
75W		

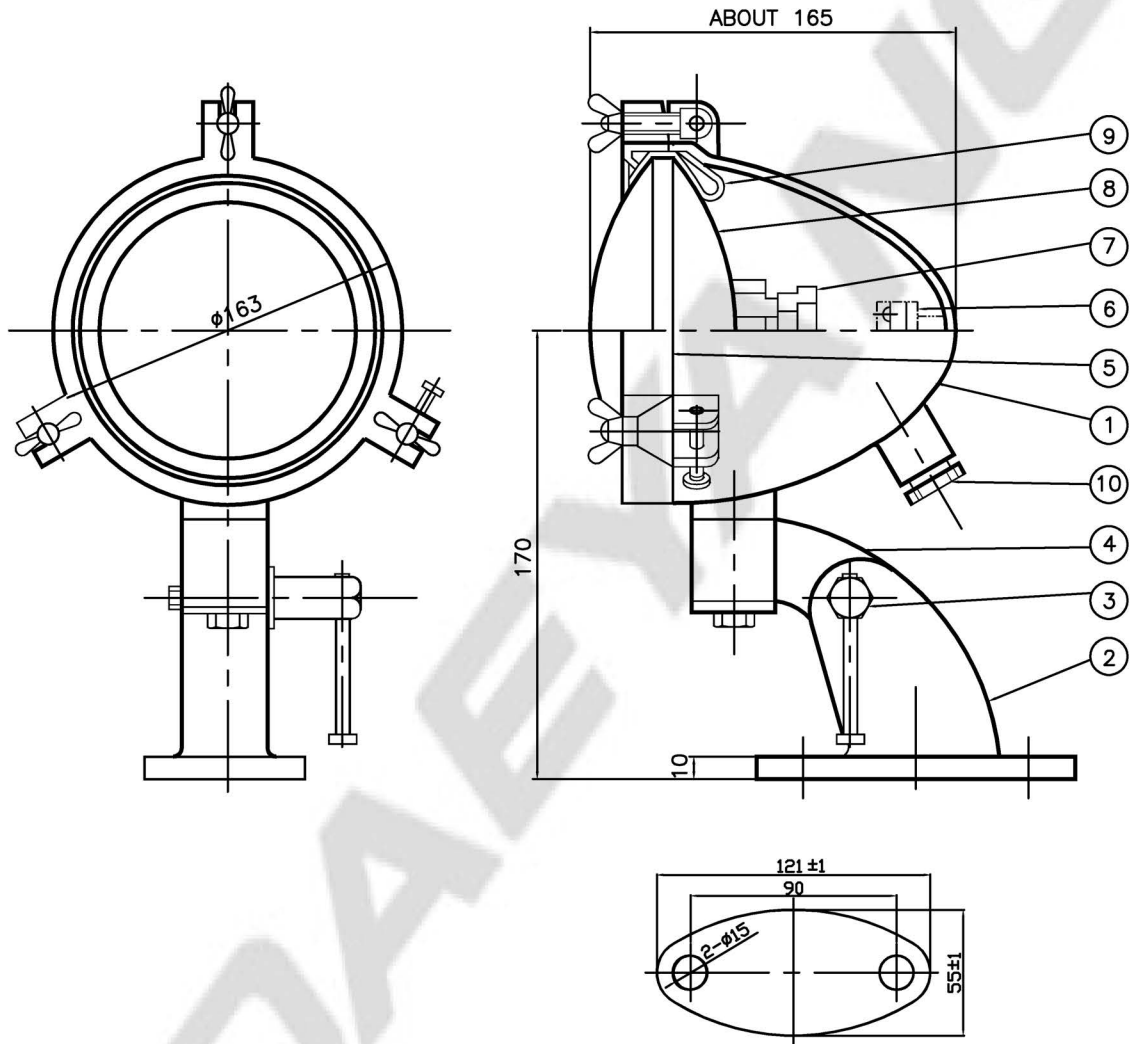

SETTING BASE & DIMENSION

10	CABLE GLAND(#20)	BRASS	1	φ12~φ15	5	FRONT COVER	BRASS	1	
9	PACKING	SILICONE	1		4	BODY HOLDER	BRASS	1	
8	SEALED BEAM LAMP	-	1	DC24V,75W	3	CLAMP BOLT	BRASS	1	
7	LAMP HOLDER	PHENOL	1		2	SETTING BASE	BRASS	1	
6	TERMINAL BLOCK	PHENOL	1	3P	1	BODY	BRASS	1	
NO	NAME OF PARTS	MATERIAL	Q'TY	REMARKS	NO	NAME OF PARTS	MATERIAL	Q'TY	REMARKS

APPROVED	B. K. KIM	UNIT	MM	TITLE;  BOAT DECK LIGHT FOR MARINE USE			
CHECKED		SCALE	N/S				
DRAWING	B. I. KIM	COLOR	N-9.3				
DATE	2015.12.04	IP	56				
				MODEL NO.	PB75I-24BWCF	WEIGHT	5.2 Kg
				DWG NO.	L47110001	SHEET NO.	29